

UM DANDIA™

Shrink-Fit Adjustable Tool Holder

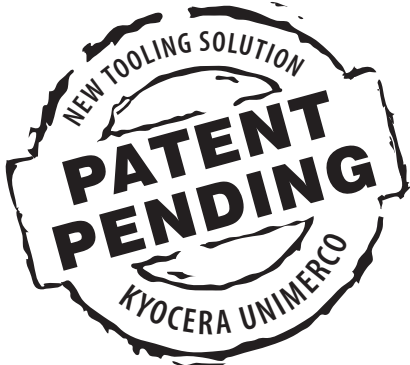

www.kyocera-unimerco.com

ADVANTAGES

■ Safe clamping of the tool

The length setting is kept, no changes in the radial runout adjustment

■ Easy to handle

Reduction of the setting time for radial runout adjustment

■ Vibration-damping effect due to compact / solid design

Higher cutting values possible

Better surface quality of the holes

Increases the tool life

■ Exact radial runout adjustment of the tool

Reduces the machine runout errors

Increases the tool life

■ Configureable to your needs

You can use the tool holder with MQL or water coolant

If needed you can also add colour-marking

■ Standard sizes with short delivery time

The tool holder comes in many standard sizes - please see below

We can also supply the tool holders in custom sizes according to your needs.

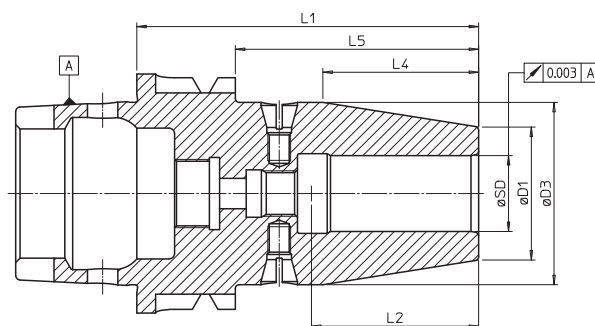
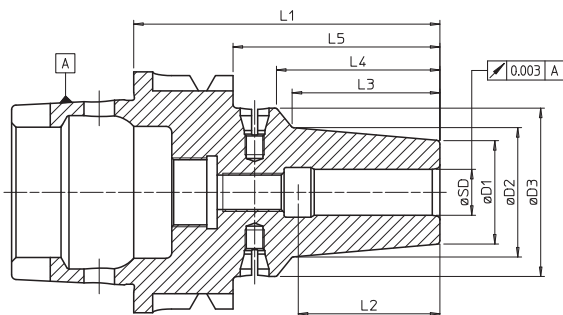

To find out more:



Mounting	øSD	øD1	øD2	øD3	L1	L2 (MQL)	L2 (WET)	L3	L4	L5
HSK63-A	8	24	30.6	42	75	32	30.7	31	35.7	49.05
	10	24	30.6	42	75	32	30.7	33	37.7	49.05
	12	27	33.8	44	80	37	35.7	38.6	42.7	54.05
	14	27	33.8	44	80	37	35.7	38.6	42.7	54.05
	16	35	-	48	90	44	42.7	-	41	64.05
	18	35	-	48	90	44	42.7	-	41	64.05
	20	35	-	48	90	44	42.7	-	41	64.05
	25	40	-	48	100	54	51.7	-	51.2	74.05